

# EFFECT OF SODIUM HYPOCHLORITE ON THE STRUCTURAL INTEGRITY OF POLYETHYLENE PIPES FOR POTABLE WATER CONVEYANCE

D. Castagnetti<sup>°</sup>, E. Dragoni<sup>°</sup>, G. Scirè Mammano<sup>°</sup>,  
N. Fontani\*, I Nuccini\*, V. Sartori\*

<sup>°</sup> Department of Engineering Sciences and Methods  
University of Modena and Reggio Emilia  
Via Amendola, 2 – Pad. Morselli  
42100 Reggio Emilia (Italy)

\* ENIA S.p.A.  
Via Nubi di Magellano, 30  
42100 Reggio Emilia (Italy)

## ABSTRACT

An experimental research is presented aimed at determine the effect of disinfectants on high density polyethylene (HDPE) pipes, commonly employed in modern urban networks for water conveyance. The test campaign is oriented to the analysis of PE100, for alimentary use, with a nominal diameter DN 32. The effect of sodium hypochlorite at a constant concentration of 2.5 ppm is investigated, by applying non severe environmental conditions. The exposure is performed through an experimental plant specifically implemented, which consists of two separate lines, a chlorinated and a neutral one. On each line both samples from the pipe and dog bone specimens can be simultaneously exposed. A comparison is presented between the results of this test campaign and a former one investigating the effect of chlorine dioxide. It is shown that chlorine dioxide is much more aggressive on polyethylene than sodium hypochlorite. The mechanical properties of the pipe, however, are not affected by both type of disinfectants as testified by tensile tests and pressure tests at constant temperature. A fast and simple mechanical characterization by means of ring specimens is also investigated.

**KEYWORDS:** high density polyethylene pipe, sodium hypochlorite, chlorine dioxide, structural integrity

## 1. INTRODUCTION

This paper deals with the effect of chlorine on the structural integrity of polyethylene pipes for potable water conveyance. Water potability and quality up to consumer, in urban networks for water conveyance, is commonly ensured by means of chlorine disinfectants. Such treatments provide high germicide power, reliability, and efficiency. Moreover they can be applied also for wide networks because the effect of the treatment is steady. On the other hand free chlorine released by the disinfectant produces a strongly oxidative environment that affects all components of the network. The oxidative effect is more severe with increasing temperature.

High density polyethylene (HDPE) pipes have been widely employed in recent urban networks for water conveyance, due to their advantages in setting up, joining and toxicology safety. In addition polyethylene pipes are guaranteed for a long life time.

Three are the aims of this work. As first to assess whether chlorine, which is employed to assure water potability, affects the structural and chemical integrity of polyethylene pipes. Secondly to compare different disinfectants in order to classify their aggressiveness on polyethylene. Finally to detect a fast test method, which can be used as acceptance criterion once the pipe reaches the field, to assess the material strength.

The research is backed by a local multi-utility company supplying potable water and other services in different districts (ENIA S.p.A.). The company has observed a significative difference in the average lifetime between PE pipes of the same material lying in different positions along the conveyance network and exposed to different disinfection modes.

Many researches have been published investigating the effect of chlorine for water disinfection on PE pipes for water conveyance. Andersson et al [1] show that even low concentration of chlorine produces an highly oxidative environment leading to significant pipe lifetime decrease. Moreover, it seems that antioxidants introduced in the blend are not able to provide resistance to chlorine effect by themselves only. Hassinen et al [2] demonstrate that antioxidants introduced in HDPE are rapidly consumed by chlorinated water at high temperatures. A technical report from Plastic Pipes Institute (3), based on many experimental tests, refers that polyethylene pipes are not affected by exposure to chlorinated water. Gill et al [4] show that crosslinked polyethylene (PEX) is affected by a remarkable lifetime decrease in case of exposure to hot chlorinated water. The effect seems to correlate well with the oxidation-reduction potential of water. Vibien et al [5] detect a significant influence of chlorine on PEX mechanical properties, even at very low concentration. However the PEX pipe material appears to have good resistance to chlorinated potable water. Brodgen et al [6] provide an extrapolation technique for determining lifetimes in an industrial application of a PE 100 pipe grade including welds and a PVC-U pipe grade exposed either to sodium hypochlorite or hydrogen peroxide.

From the literature review it appears that a vast majority of the researches agrees on the aggressiveness of chlorine on the chemical integrity of PE, while the mechanical degradation of PE is not unanimously recognized. In a previously published paper presented at Plastic Pipes XIII [7] the authors described the design of an experimental plant to expose pipe samples and specimens to different disinfectants. In the same paper were presented the first results of an experimental campaign aimed at assessing the effect of chlorine dioxide on PE pipes. This work continues that research by reporting the final results of the experimental campaign on chlorine dioxide. Moreover it presents the results of a new experimental campaign that investigate the effect of sodium hypochlorite on polyethylene. This campaign was performed on the same exposure plant described in [7].

With respect to previous researches in the field, this work is oriented in assessing the effect of sodium hypochlorite on PE pipes by means of a systematic experimental campaign. The test campaign, which continued for one year, was defined in accordance with the design of experiment criteria. Both pipe samples and specimens were exposed in the plant at not extreme conditions in order to resembles the most critical environmental conditions occurring in real conveyance networks. Finally it is highlighted that simple and fast experimental tests are seek that could be employed to investigate if degradation phenomena are going to arise on the material.

The paper presents the layout of the experimental plant, the different exposure conditions that it can realize (to chlorinated and non chlorinated water), and the type of specimens that it can process (pipe or dog-bone specimens). The experimental campaigns performed are described, in particular the new one, aimed at investigating the effect of sodium hypochlorite on polyethylene. On each specimen sampled during the experimental campaign a mechanical and a chemical characterization are performed with monotonic tensile test up to failure and oxidation induction time (OIT) test. The monotonic tensile test, in particular, is performed both on dog-bone specimens (conform to ISO 6259 [8-9]) and on ring specimens extracted by the pipe. On pipe samples exposed to chlorine dioxide is also performed a pressure test at constant temperature (conform to UNI EN 921 [10]).

The results show that chlorine dioxide is much more aggressive on polyethylene with respect to sodium hypochlorite. In the pipe itself, however, it is not observed a significant decrease of the mechanical and chemical properties for both type of disinfectants. The dog-bone specimens, fully immersed in chlorinated water, on the contrary show a fragile behaviour in the tensile test, and also a rapid antioxidants consumption when exposed to chlorine dioxide. The tensile tests on ring specimens do not to provide a clear correlation with the pipe exposure and further investigation are needed.

## 2. METHOD

### 2.1. Test plant

The experimental plant has been specifically designed in order to efficiently and fully implement an experimental campaign aimed at studying the effect of chlorine on PE. The leading design criteria are described in [7].

In Figure I it is presented a functional layout of the plant. The plant consists of two separate lines (A and B) which realize two identical testing environments, with exception of concentration of disinfectant, being respectively zero or at the target value. The water is supplied to the plant by the urban main. Chlorine is removed from the main water by means of an activated carbon filter installed on the supply line of the plant. This assures that a neutral water is supplied to the non-chlorinated exposure line.

An electric boiler is installed on an independent line to perform water heating. Heat exchange is performed by means of two plate heat exchangers, set up on this heating line. Each of them provides heat to one of the exposure lines of the plant. The water temperature can be accurately controlled and set to a constant value in each of the exposure lines. In fact the primary line of each heat exchanger can be bypassed through a specific by-pass line controlled by an automatic switch valve (BpA, BpB) operated by a PID device.

A metering pump, which can inject liquid disinfectant, is set up in the specific line to regulate the concentration of chlorine. The pump is operated by a controlling device which receives a feedback from a “redox” and pH sensor. This system assures an automatic and accurate control of the free chlorine level in the water. The free chlorine concentration is measured daily also with colorimetric method. In addition the pH level is controlled on both lines by a metering pump, operated by a controlling device that receives a feedback from an independent pH sensor, and injects an acid or a base. A controllable waste valve, which permanently spills a ratio of flowing water, equips each line. This in order to better accomplish a steady pH level and an accurate free chlorine concentration.

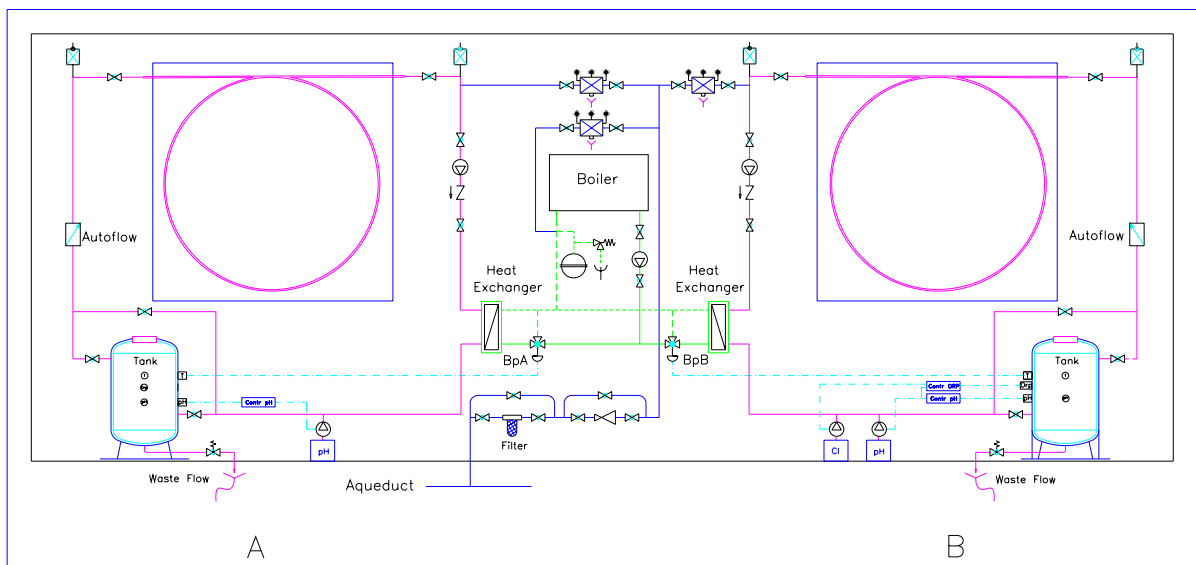

Figure I – Functional layout of the plant

All the plant is made with AISI 316 stainless steel, with exception of a few bronze or brass components and all the joints are screwed. Monitoring of the functionality of the plant is performed automatically by means of a PC, equipped with an ad hoc acquisition software. The system stores all the most significant working parameters and activates warnings if one of these parameters goes out of the defined range.

The plant performs two different exposure conditions: to neutral water and to chlorinated water. Moreover on each exposure line of the plant polyethylene is tested in two different conditions: directly as pipe or in the form of dog-bone specimens conform to ISO 6259 [8-9].

The pipe was directly exposed serially in the line, in the form of a complete coil (off the shelf) or partly (Figure II), with water flowing inside it at the same pressure as in the plant. Thermal insulation

was obtained by accommodating the hank in a wood cage coated with expanded polyurethane. Thus a constant temperature of the water all along the coil is ensured.

Dog-bone specimens were placed in an isolated tank accessible from the top. The tank is placed serially in the exposure line and the entire volumetric capacity of the line flows steadily in it. However the water speed in the tank was almost zero due to its wide diameter. The specimens were accommodated in a specific basket hanged in the tank, in order to provide a proper water flow on each surface (Figure III).



Figure II – Pipe coil in the plant



Figure III – Basket with specimens

## 2.2. Experimental campaigns

The experimental campaign consists in two systematic test campaigns performed by means of the exposure plant previously described. These experimental campaigns were oriented to the analysis of polyethylene pipes PE100, for alimentary use, with a nominal diameter DN32 and nominal maximum pressure PN25. The pipe was exposed both as sample and as tensile specimen.

The first experimental campaign started at the beginning of 2006 and lasted one year. It investigated the effect of chlorine dioxide disinfectant at a constant concentration of 5 ppm, in order to obtain a free chlorine concentration of about 2.5 ppm. All the test conditions and scheduling were accurately described in a previous work presented by the authors [7].

The second experimental campaign started in spring of 2007 and ended in spring of 2008. It was aimed at investigating the effect of sodium hypochlorite disinfectant at a constant concentration of 2.5 ppm (realizing the same concentration of free chlorine).

As in the first campaign the water temperature was set at a constant value of 40°C on both lines, with an accuracy of 0.1°C. This temperature represents a good trade-off between the need to speed up the decay process and the requirement that it does not differ too much from the real environmental conditions for typical pipe usage. The pH level was kept at a constant value of 7.1, with an accuracy of 0.1, by adjusting it by means of nitric acid (HNO<sub>3</sub>). The average pressure in the plant was 2.5 bar, giving a circumferential stress, in the pipe wall, equal to 1.2 MPa. The volumetric flow rate in the plant was 3.0 m<sup>3</sup>/h, with an accuracy of 0.2 m<sup>3</sup>/h, resulting in a water speed of 1.78 m/s along the line. The volume of discharged water ranged from 5 to 10 litre per hour, corresponding to 0.3% of the volumetric flow rate.

All the dog-bone specimens processed in the test campaign were obtained from a part of pipe, about 60 cm long. The pipe was preliminary divided into three pieces of equal length and then, each of them, cut along a longitudinal plane. As a consequence 6 specimens were obtained overall, through the cutting die thus allowing six replicates of the experimental test.

The experimental campaign lasted for one year and considered three different exposure conditions: neutral water, chlorinated water and ambient air. Exposure to neutral and chlorinated water was performed by means of the test plant. Exposure to air was performed by simply storing the material and has a double aim: as first provides the reference characteristic of the pipe naturally aged and secondly allow to monitor the effect of the consumption of the cutting die employed to extract the dog-bone specimens.

The pipe was exposed both in the form of pipe coil and as dog-bone specimens. In each tank 102 specimens were immersed, cut from the pipe before the beginning of the experimental test. A pipe coil and dog-bone specimens, respectively of the same length and in equal number as in the plant, were exposed to air. Also the batch of specimens acting as neutral reference was obtained entirely before the beginning of the campaign. All the polyethylene pipe tested in both the experimental campaigns comes from the same coil, 100 m long.

The extractions, both of the specimens and of the samples from the pipe coils, were scheduled every 3 days the first three times, once a week the following three times, then every 14 days again for three times and finally with a span of about 2 months. At each sampling six dog-bone specimens were extracted from the reference batch exposed to air (VA), from the non-chlorinated tank (VB) and from the chlorinated one (VC). From each coil a piece of pipe, about 60 cm long was cut, so as to obtain six specimens according to ISO 6259-3, as described before. These were called respectively (TA) for the reference pipe exposed to air, (TB) for the pipe in the non-chlorinated line and (TC) for the pipe in the chlorinated one. In addition, from the same piece of pipe, three ring specimens were cut, by tooling machine. The ring specimens, which have an axial length of 8 mm, were called respectively (AA) for the reference pipe exposed to air, (AB) for the pipe in the non chlorinated line and (AC) for the pipe in the chlorinated one.

The investigation of the effect of chlorine was carried out by means of mechanical and chemical characterization, respectively monotonic tensile test and OIT test. The quasi-static, monotonic tensile test was carried out on an electromechanical testing machine (Galdabini SUN 500) with a load capacity of 5 kN. The machine operation is controlled by a PC, equipped with proprietary data acquisition software. For the dog-bone specimens the test conditions were similar to ISO 6259-1/3 [8-9]. The test speed was set to 50 mm/min. As a main departure from the standard, the elongation of the specimen was measured indirectly on the basis of the displacement of the moving crosshead. Since the deformation of the heads of the specimens was minimal, this is considered to have had a modest effect on the quality of the results.

Also the ring specimens extracted from the pipe coil were tested through a quasi-static-monotonic tensile test up to failure. The rings were loaded by their inner surface using two circular semi-disks at opposite sides (Figure IV). All the mechanical tests have been performed at a temperature between 21 and 30°C.

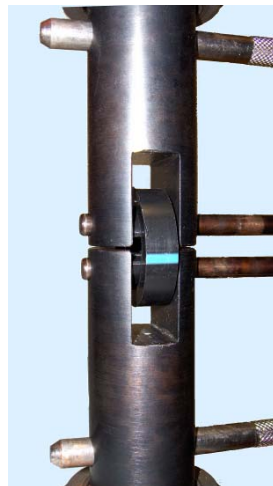

**Figure IV** – Tensile test on ring specimen

The OIT test was performed on the same batches of the dog-bone specimens with exception of TA (the reference pipe exposed to air) by performing three replicates. The sample for the OIT test was obtained by trimming with a sharp tool, from one head of the dog-bone specimen, a cylindrical specimen with 6 mm diameter. Two disks, one on the surface corresponding to the internal side of the pipe and the other in the middle layer, were extracted and tested with the differential calorimeter (at a temperature of 210°C) giving their OIT values.

As further mechanical characterization pressure tests at constant temperature were performed on pipe samples exposed, in the first campaign, to chlorine dioxide. Two pipe samples (about one meter

long) from each of the batches TA, TB and TC were tested respectively for a total of 6 specimens. The tests were performed by the Plastic Italian Institute according to UNI EN 921 [10], at a constant temperature of 80°C, up to a maximum time period of 2000 hours.

**3. RESULTS**

This section presents the results of both the experimental campaigns performed on the test plant in the last three years. The results of the experimental campaigns regard the mechanical and chemical characterization performed on the specimens that have been sampled during the exposure. A comparison between the two type of disinfectant is also provided.

Figure V and VI present the mean value of percentage elongation at failure,  $\epsilon_f$ , as a function of time (days). The results are displayed for each type of exposure both for the campaign investigating the effect of chlorine dioxide (Fig. V) and for the one on sodium hypochlorite (Fig. VI).

The diagrams of Figure VII and VIII display the oxidation induction time, on the inner surface of the pipe wall, as a function of time (day). Again Figure VII refers to chlorine dioxide while Figure VIII refers to sodium hypochlorite.

Similarly, the diagrams of Figure IX and X show the oxidation induction time, on the mid layer of the pipe wall, as a function of time (day). Again Figure IX refers to chlorine dioxide while Figure X refers to sodium hypochlorite.

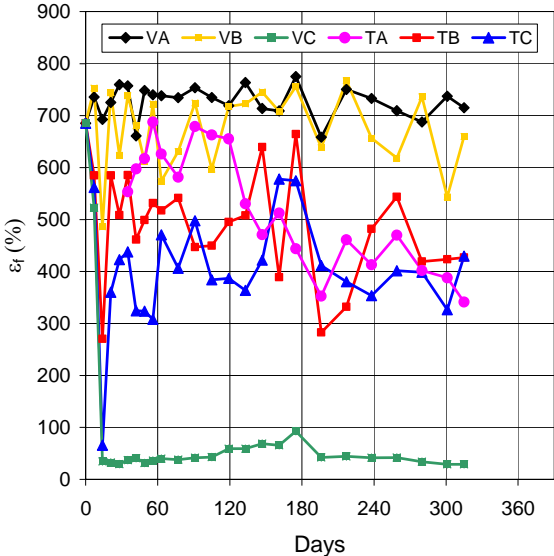

**Figure V** – Percentage elongation at failure,  $\epsilon_f$  vs exposure day for chlorine dioxide

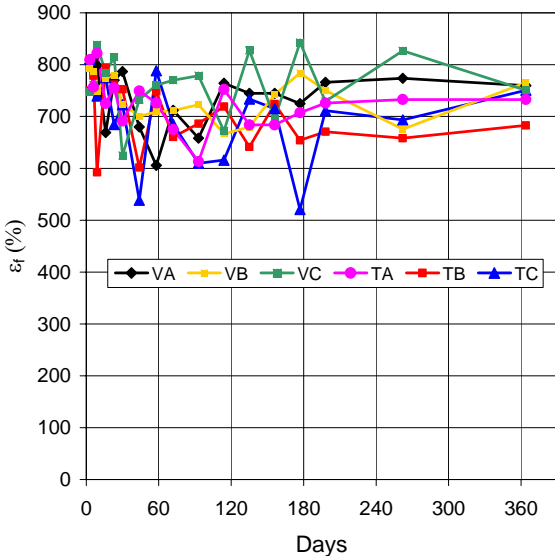

**Figure VI** – Percentage elongation at failure,  $\epsilon_f$  vs exposure day for sodium hypochlorite

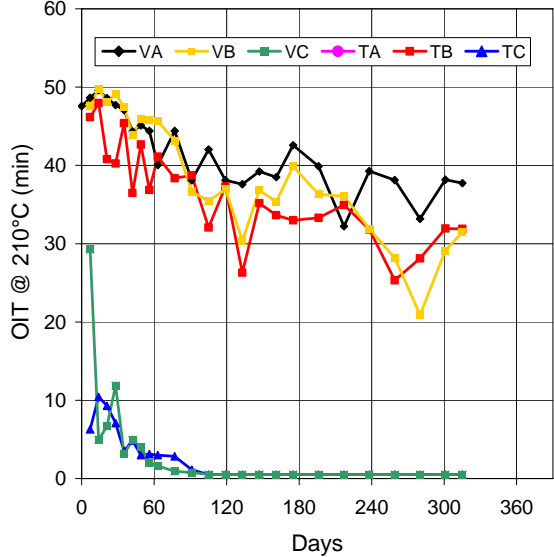

**Figure VII** – OIT inner surface vs day for chlorine dioxide

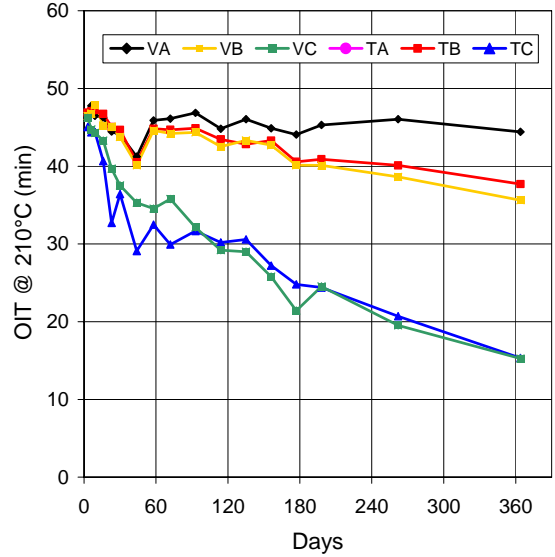

**Figure VIII** – OIT inner surface vs day for sodium hypochlorite

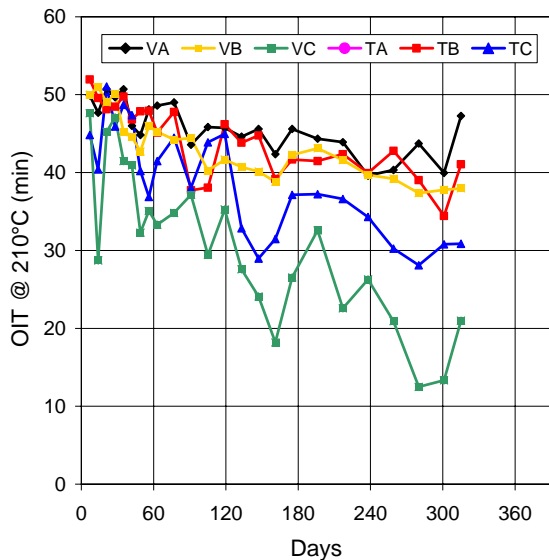

Figure IX – OIT mid layer vs day for chlorine dioxide

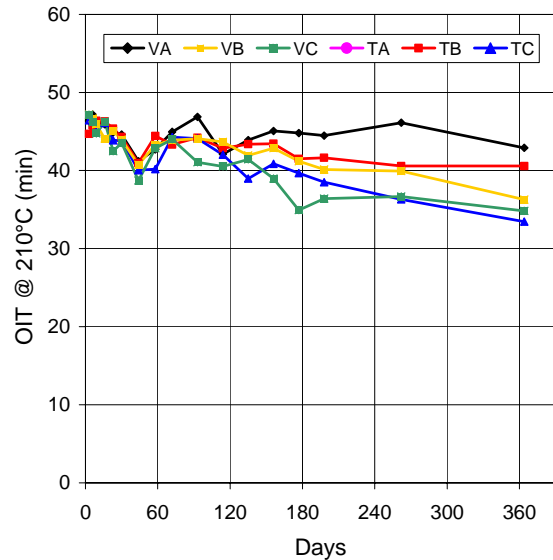

Figure X – OIT mid layer vs day for sodium hypochlorite

In Figure XI a detail of the inner surface of the specimens is displayed, highlighting the difference between the one exposed to chlorine dioxide (A), the one to non-chlorinated water (B) and the one exposed to sodium hypochlorite (C).

The bar chart of Figure XII provide a comparison between the effect of chlorine dioxide and sodium hypochlorite on the elongation at failure and oxidation induction time (respectively on the mid layer and inner surface). The results refer to the last sampling of the experimental campaigns and are provided in terms of average values.

Figure XIII presents a bar chart reporting the average values of the percentage elongation at failure,  $\epsilon_f$ , of the ring specimens at the end of the experimental campaign (the last sampling). Each bar corresponds to one of the exposure conditions of the pipe during the experimental campaign (TA, TB and TC respectively). The chart collects both the results from the specimens exposed to chlorine dioxide ( $\text{ClO}_2$ ) and to sodium hypochlorite ( $\text{NaClO}$ ).

Table I summarizes the results of the pressure tests at a constant temperature of  $80^\circ\text{C}$  performed by the Plastic Italian Institute on two pipe samples for each of the batches TA, TB and TC. All the tests were stopped at 2000 hours without observing any failure on the pipe samples.

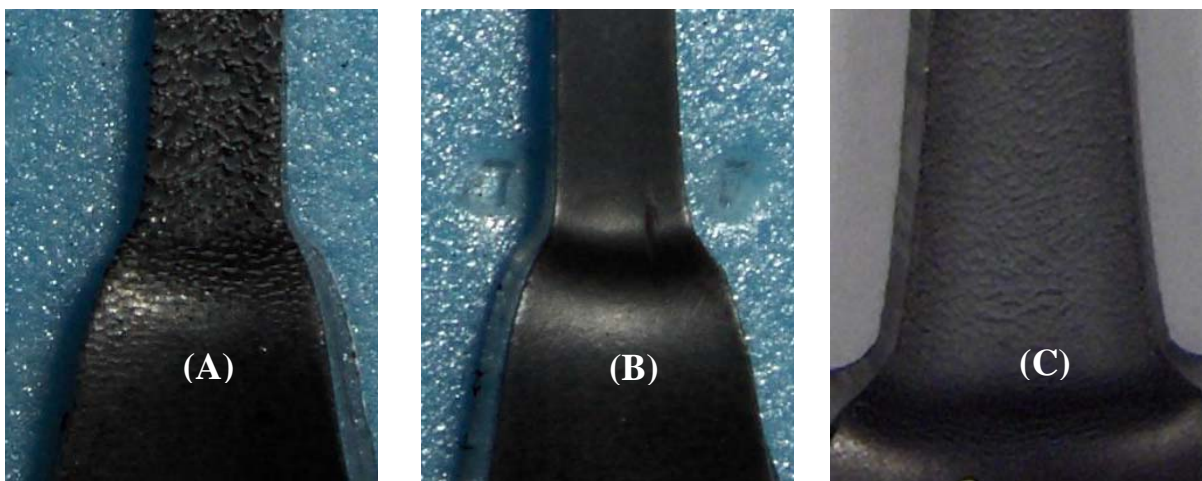
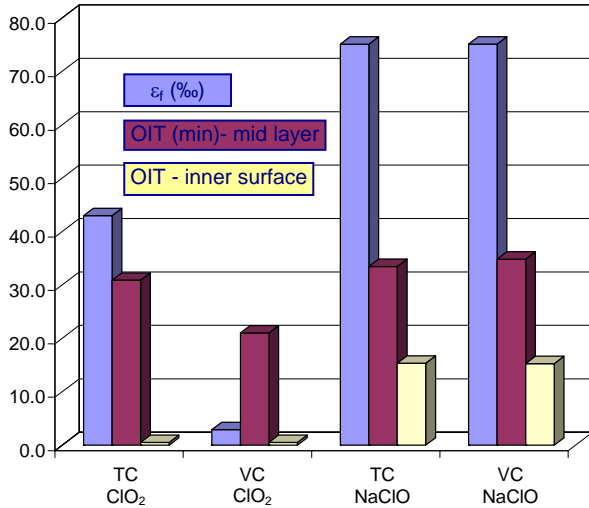
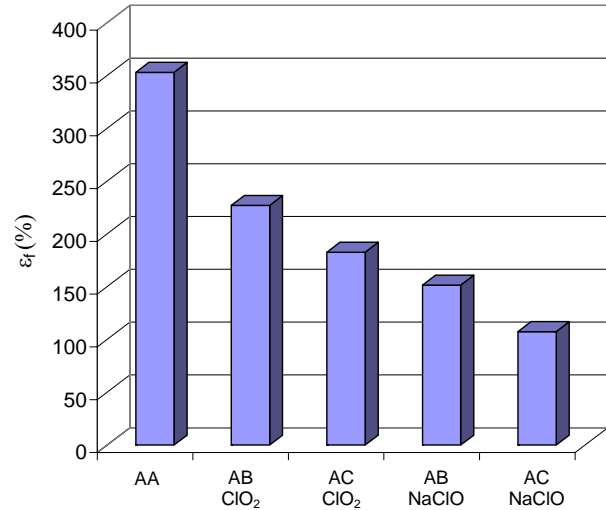

Fig. XI – Detail of specimens exposed to chlorine dioxide (A) neutral water (B) and sodium hypochlorite (C)



**Fig. XII** – Bar chart of comparison between the experimental test campaigns



**Fig. XIII** – Bar chart of the percentage elongation at failure of ring specimens

**Table I** – Results of the pressure tests at constant temperature of 80°C

	Time (h)		
	165	1000	2000
<b>TA 1</b>	passed	passed	passed
<b>TA 2</b>	passed	passed	passed
<b>TB 1</b>	passed	passed	passed
<b>TB 2</b>	passed	passed	passed
<b>TC 1</b>	passed	passed	passed
<b>TC 2</b>	passed	passed	passed

#### 4. DISCUSSION

By observing the diagrams of Figure V and VI it appears a great instability of the elongation at failure,  $\epsilon_f$ , in both the experimental tests. Also the scatter of the results at each sampling (not reported here for clarity) was quite high. The greater reduction of the elongation at failure is observed for the VC specimens exposed to chlorine dioxide (Figure V). Since the second week of testing a decrement of 90% was registered and then remains almost constant up to the end of the test period. This drastic reduction could be attributed to the severe exposure condition of these specimens which are fully immersed and exposed to chlorine effect on both inner, outer and side surfaces. With regard to TA, TB, and TC specimens (Figure V), after an initial phase of high instability, they show a decrease of about 50% in the elongation at failure, in particular at the end of the test campaign. This decrease is mainly due to the consumption of the cutting die because it is almost the same both for the TA and for the TB and TC specimens. The effect of the exposure to chlorinated or non-chlorinated water, on the contrary, does not appear significantly. Finally, the response of VA and VB specimens (Figure V) is quite similar in terms of elongation at failure all along the test campaign. The response of the VB specimens is only a little lower to that of the reference batch (VA), and largely unstable. This could be attributed to the combined effect of water and temperature.

By observing the diagram of Figure VI it appears, on the contrary, that sodium hypochlorite does not produce a significant decrease in the elongation at failure of the specimens. Their response becomes almost steady towards the end of the test campaign, without significant differences between the batches.

In the diagrams of Figures VII and VIII it appears a similar behaviour of the specimens. In both of them it is observed a decrease in the OIT, at the inner surface, for VC and TC specimens. In the case of exposure to chlorine dioxide (Figure V) the decrease of both of them is abrupt since the second week of test. Then, the OIT value becomes stable at 90% less than its initial value from the second

month of exposure up to the end of the test campaign. A similar trend is observed for the VC and TC specimens exposed to sodium hypochlorite (Figure VIII). It appears a monotonic decrease of their OIT value up to 60% at the last sampling. Also the other batches (VA, VB and TB) show a lowering of the OIT, in particular in the first test campaign (Figure VII). Here a maximum reduction of 30% is observed. In comparison, in the second test campaign (Figure VIII) the specimens aged in air (VA) provide quite constant OIT values. On the contrary a slight decrease, up to a maximum of 20%, is observed in the VB and TB specimens. This testifies that both the dog-bone specimens and the pipe are equally subjected to antioxidants consumption on their inner surface.

By observing Figures IX and X it is highlighted that the decrease in the OIT on the mid layer of the pipe wall is quite low both for exposure to chlorine dioxide and for sodium hypochlorite. A slight different behaviour is observed for the TC and VC specimens exposed to chlorine dioxide (Figure IX). TC specimens show a slight reduction while the VC specimens show a clear decrease of the OIT.

On the whole from the former observation it emerges that chlorine dioxide is more aggressive on polyethylene than sodium hypochlorite. This appears both with respect to elongation at failure (Figure V and VI) and with respect to antioxidant consumption (Figure VII-X). In addition the differences between the disinfectants are also attested by the different aspect of surfaces of the specimens after the tensile test, as shown in Figure XI. (Figure XI-(A)) presents a specimen obtained from the pipe exposed to chlorine dioxide, (Figure XI-(B)) from the pipe exposed to neutral water, and (Figure XI-(C)) from the one exposed to sodium hypochlorite. In Figures XI-A and C the surfaces appears quite rough testifying a detrimental effect of chlorine on polyethylene. The higher degradation of the surface, however, is observed on the specimen of Figure XI-(A), exposed to chlorine dioxide. In both the experimental campaigns the degradation, either mechanical or chemical, is more significant on the dog-bone specimens which appear more vulnerable than the pipe. As further observation it is highlighted that it does not appear a correlation between the elongation at failure and the consumption in the antioxidants as can be seen by comparing the diagrams of Figures V and VI with Figures VII and VIII respectively.

These observations are highlighted in the bar chart of Figure XII. The direct comparison, at the last sampling of each test campaign, emphasizes the lower elongation at failure and OIT values of the specimens exposed to chlorine dioxide with respect to the ones exposed to sodium hypochlorite.

The bar chart of Figure XIII shows that the test on the ring specimens did not provide clear results. While the specimens exposed to air (TA) present a quite higher elongation at failure, the ones exposed to sodium hypochlorite, both TB and TC, provide the lower response. Even considering response of the ring specimens as a function of time for the whole test period (not reported here for the sake of brevity), it was not possible to perceive a univocal trend between the different types of disinfectants. Further investigations will be performed in order to understand if this simple and fast test method could provide useful information.

From Table I it appears that, as said before, the mechanical properties of the polyethylene pipe are not affected by the exposure to chlorine. The pressure tests at constant temperature were accomplished up to 2000 hours by all the pipe samples (both exposed to air (TA), to neutral water (TB), and to chlorine dioxide (TC)).

As final remark, it appears that the dog bone specimens seems very susceptible to chlorine. The pipe, on the contrary, even if presents significant antioxidants consumption, is not affected in terms of mechanical resistance. This is testified both by the tensile test on dog-bone specimens and, in particular by pressure test at constant temperature. The higher mechanical performance of the pipe could be attributed to the presence of a protective layer on the inner pipe surface. Probably this layer originates during the extrusion process and reduces the vulnerability of the pipe with respect to the base material. Further investigations will be performed to enforce this hypothesis that highlight the importance of this manufacturing process.

## 5. CONCLUSIONS

This work presents an experimental research investigating the effect of disinfectants on high density polyethylene (HDPE) pipes, commonly employed in modern urban networks for water conveyance. Through an experimental plant specifically implemented, a test campaign, investigating the effect of sodium hypochlorite at a constant concentration of 2.5 ppm is performed. The test campaign is oriented to the analysis of PE100, for alimentary use, with a nominal diameter DN 32.

The monotonic tensile tests up to failure and OIT tests highlight that there is no substantial influence on the mechanical behaviour of PE and a slight antioxidants consumption. Much more aggressive appeared, from a previous test campaign, chlorine dioxide, which determines, after a few weeks of exposure, a dramatic antioxidants consumption. Also the elongation at failure of the dog-bone specimens was drastically reduced. The mechanical properties of the pipe, however, were not affected by the exposure to disinfectants, as testified by tensile tests and pressure tests at constant temperature. Further investigations will be needed to understand the cause of the higher strength of the pipe with respect to the dog-bone specimens

## ACKNOWLEDGEMENTS

The support of FAST S.p.A., and in particular of eng. Emilio Benati, in providing the hardware and software for data acquisition and plant monitoring, is gratefully acknowledged.

The support of Plastic Italian Institute (IIP) in the execution of the pressure tests at constant temperature on the pipe samples from the first experimental campaign is gratefully acknowledged.

## REFERENCES

1. U. Andersson and M. Ifwarson, “*What controls the lifetime of plastic pipes and how can the lifetime be extrapolated*”, Proceeding of Plastic Pipes XI, Munich, Germany, 2001.
2. J. Hassinen, M. Lundback, M. Ifwarson, U.W. Gedde, “*Deterioration of polyethylene pipes exposed to chlorinated water*”, Polym. Degrad. Stab., 84, 261, 2004.
3. Plastics pipe institute “*Effect of chlorine disinfection on PE water pipe*”
4. S. Gill, R. J. Knapp, S. W. Bradley, and W. L. Bradley, “*Long term durability of crosslinked polyethylene tubing used in chlorinated hot water systems*”, Proceeding of Plastic Pipes X, Goteborg, SUEDE, vol 28(6), 309-313, 1999.
5. P. Vibien, J. Couch and K. Oliphant, “*Assessing Material Performance in Chlorinated Potable Water Applications*”, Book – Institute of Materials, 759, 863-872, 2001
6. S. Brodgen, “*The lifetimes of PE and PVC materials for use in sodium hypochlorite and hydrogen peroxide environments*”, Proceeding of PPXII, 2004.
7. D. Castagnetti, E. Dragoni, G. Scirè Mammano, N. Fontani, I. Nuccini, V. Sartori (2006) “*Effect of chlorinated water on the mechanical strength of polyethylene pipes*”, Proceedings of Plastic Pipes XIII, October 02–05, Washington, DC, USA.
8. ISO 6259 “*Thermoplastic pipes – Determination of tensile properties – Part 1: General test method*”
9. ISO 6259 “*Thermoplastic pipes – Determination of tensile properties – Part 3: Polyolefin pipes*”
10. UNI EN 921 *Plastics piping systems-Thermoplastics pipes-Determination of resistance to internal pressure at constant temperature.*